

Setting Out Guidelines

guidance to the setting out of audience seating

The Black Book

V4/12



INTRODUCTION

This document has been created as a resource for those involved in the design, planning and configuration of lecture theatres, conference and seminar rooms.

It provides a guide to the recommendations and guidelines for the specification and use of audience seating and the setting out of passive seating.

Its aim is to provide a reliable reference point to the recommendations concerning the layout and specification of specialist spectator seating products.

While every effort has been made to ensure accuracy as guidelines and regulations are subject to change this document should be considered as a guide only, to be used in conjunction with Local Authorities' recommendations and regulations where relevant.

Confirmation should always be sought prior to commencement of the design / layout from the relevant authorities.

For any additional support and information please do not hesitate to contact us:
Chart Area Seating

www.chartareaseating.com

01342 326659

info@chartareaseating.com





RECOMMENDATIONS FOR THE SPECIFICATION AND USE OF TIERED, TELESCOPIC AND DEMOUNTABLE SEATING DEFINITIONS

1.1 SEATWAY

The minimum clear space ("seatway") measured at right angles between perpendiculars as shown in the following sketches. In all the following cases the minimum dimension "A" to be 300mm however the recommended minimum value is 350mm.

Figure 1

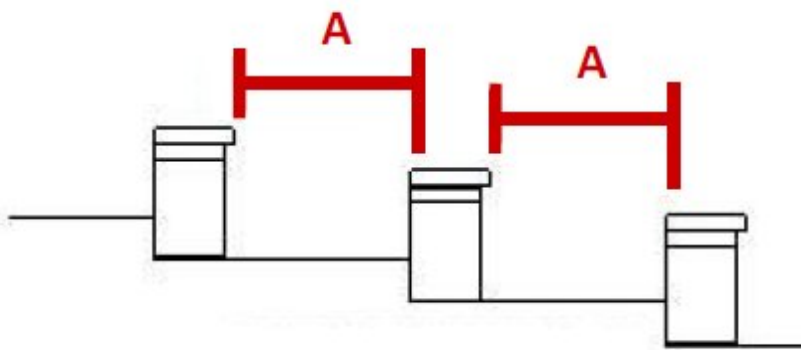

BENCH SEAT WITHOUT BACKS

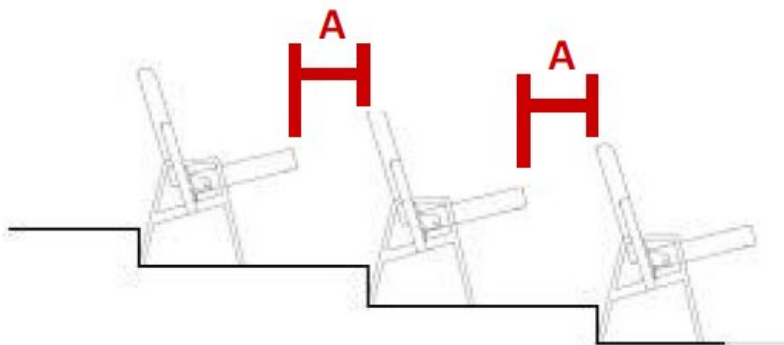

PLATFORMS WITH CHAIRS



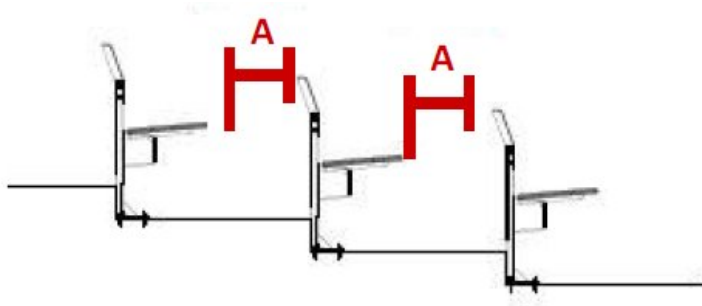

BUCKET OR NON SELF TIPPING SEATS

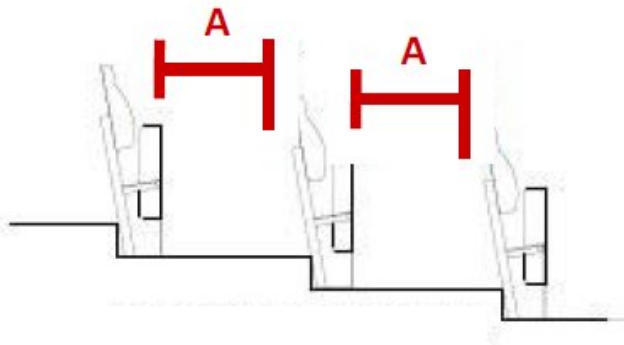

SELF TIPPING SEATS WITHOUT ARMS

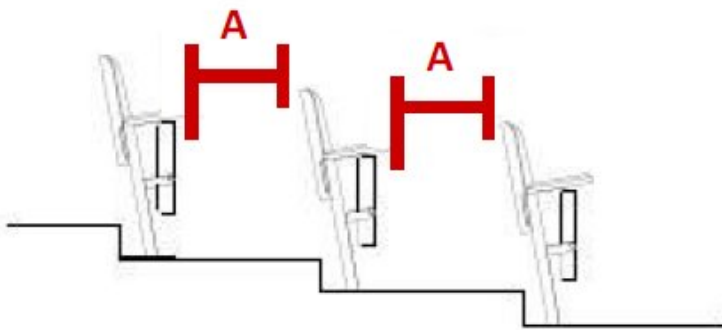

SELF TIPPING SEATS WITH ARMS



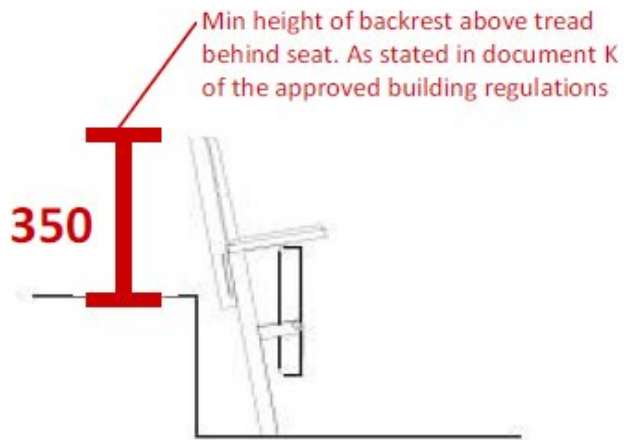

SELF TIPPING SEATS – WITH ARMS HIGH RISER

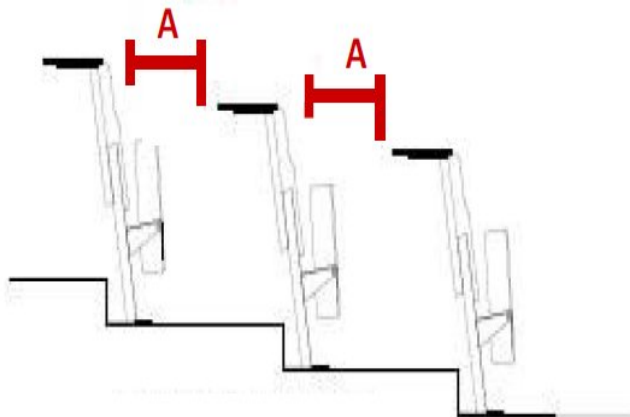

LECTURE THEATRE SEATING



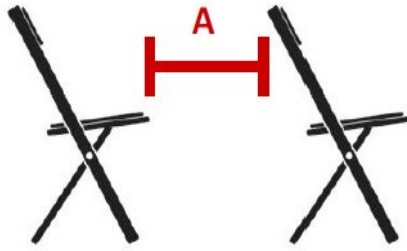

PORTABLE CHAIR – NON TIP-UP

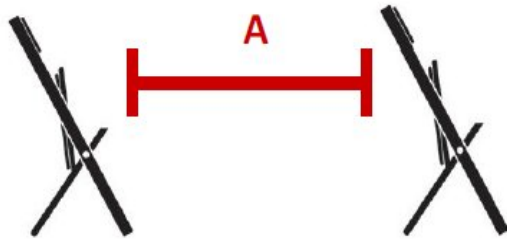

PORTABLE CHAIR – TIP UP





1.2 ROW DEPTH (Tread)

The distance 'X' measured at right angles to a riser to the top of the next riser.

Figure 2

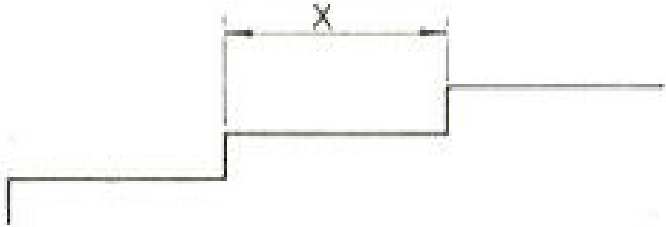

1.3 ROW RISE

The distance 'Y' measured vertically between one level of seating and the one immediately behind it.

Figure 3

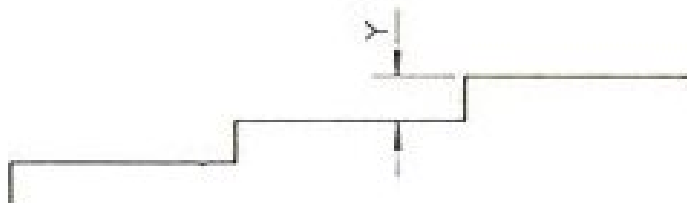

1.4 GANGWAY OR AISLE

The access space internally on a tiered seating block that provides the means of distributing people on a seating area and for evacuation from the area. In accordance with BS EN legislation. See Figure 4

1.5 LATERAL GANGWAY OR AISLE

The access space across the seating block joining two or more vertical aisles or gangways. See Figure 4





1.6 HALF STEPS(s)

An intermediate step or steps in the aisle or gangway when the row rise exceeds the allowable dimension.

Figure 4 Sectional detail showing single intermediate step

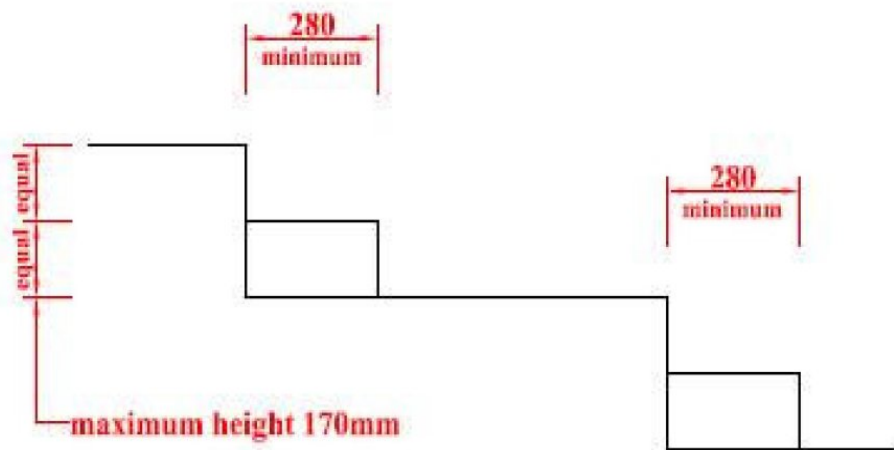
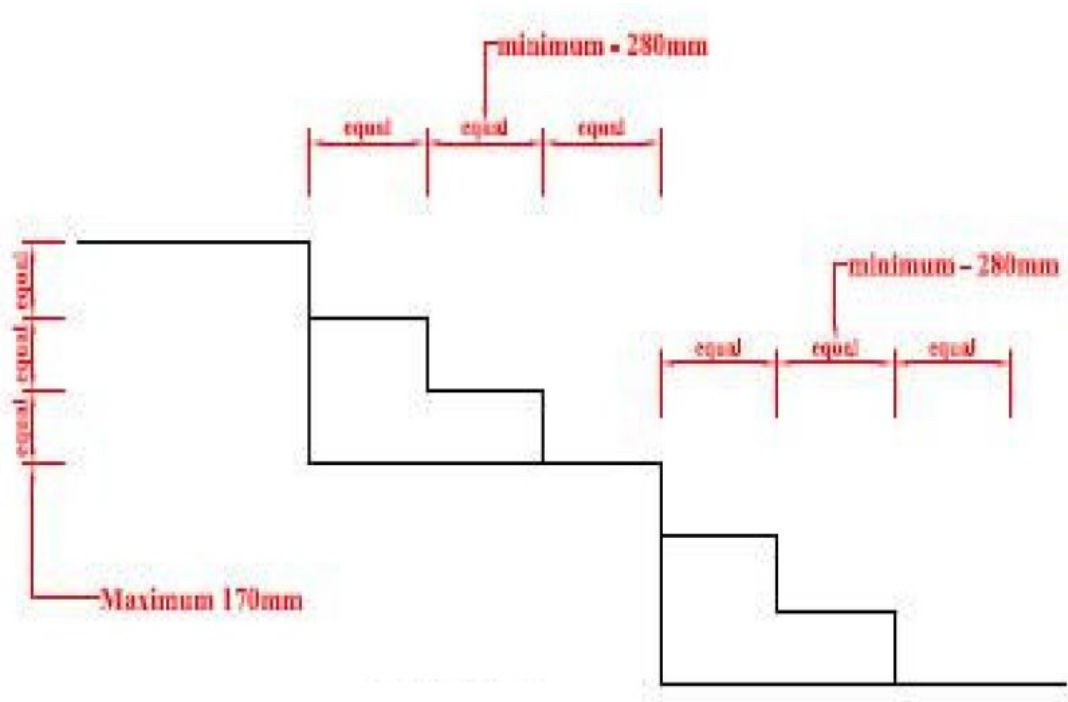



Figure 5 Sectional detail showing double intermediate step



1.7 VOMITORY OR EGRESS

The space beneath a stand allowing access to internal aisles or gangways.



1.8 GUARDRAIL

A safety barrier fitted to the sides, rear or front of a seating block.





1.9 STAIRWAYS

A means of providing access to platforms to front or rear of elevated seating blocks.

1.10 ULTRA-VIOLET ADDITIVE (U.V)

In the case of plastic seating units it is a stabilizing additive used to off-set the colour degradation of the units due to ultra-violet light.

1.11 FLOOR BARS (flat floor chairs)

A device to prevent the movement of floor chairs when laid out in a concert or similar configuration.

1.12 TYPICAL SEATING ARRANGEMENTS

Figure 6 Typical lecture theatre seating plan

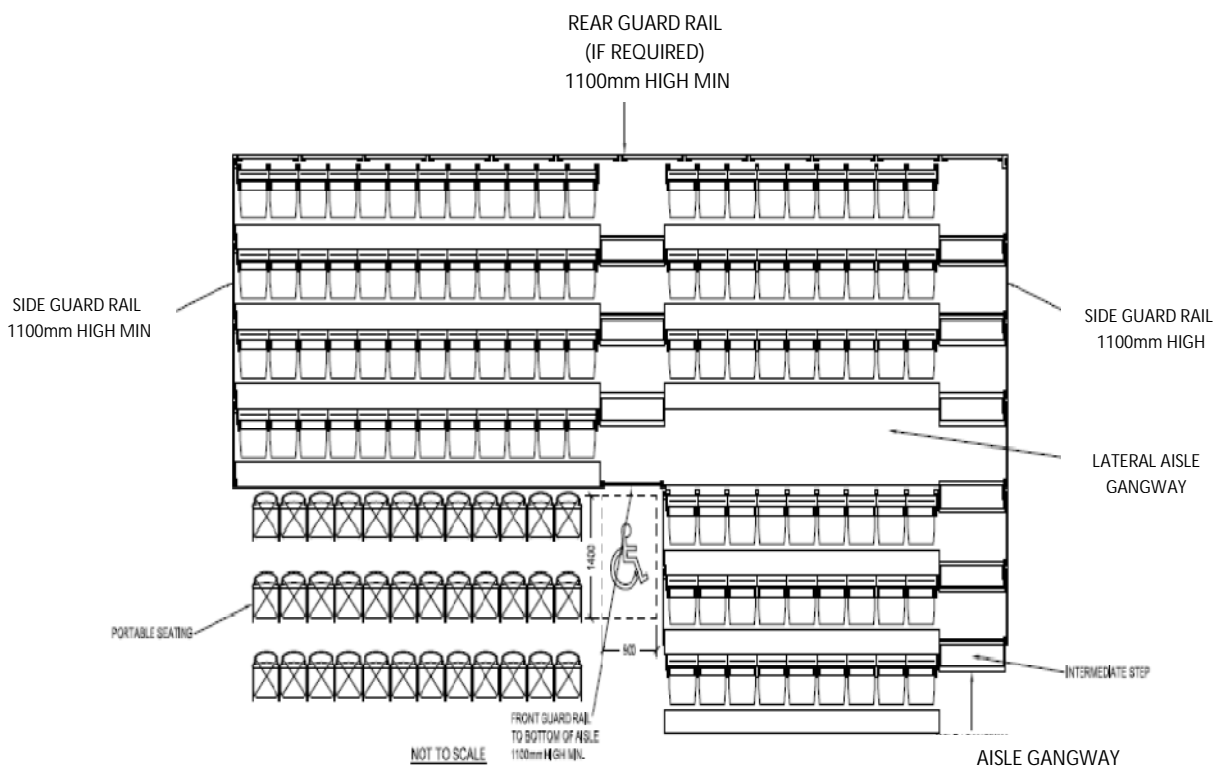



Figure 7 Typical lecture theatre sectional detail

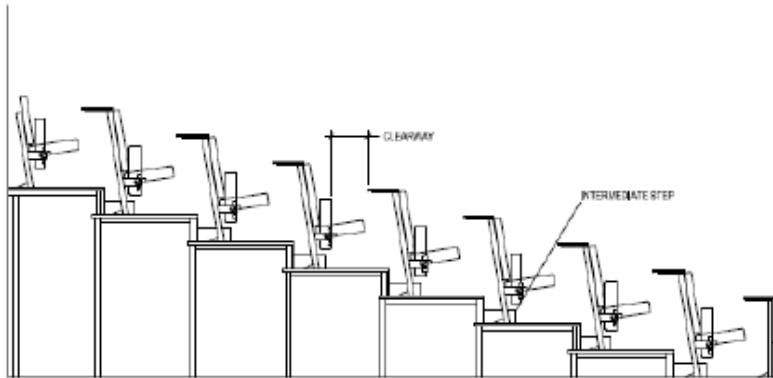

Figure 8 Typical retractable seating plan view

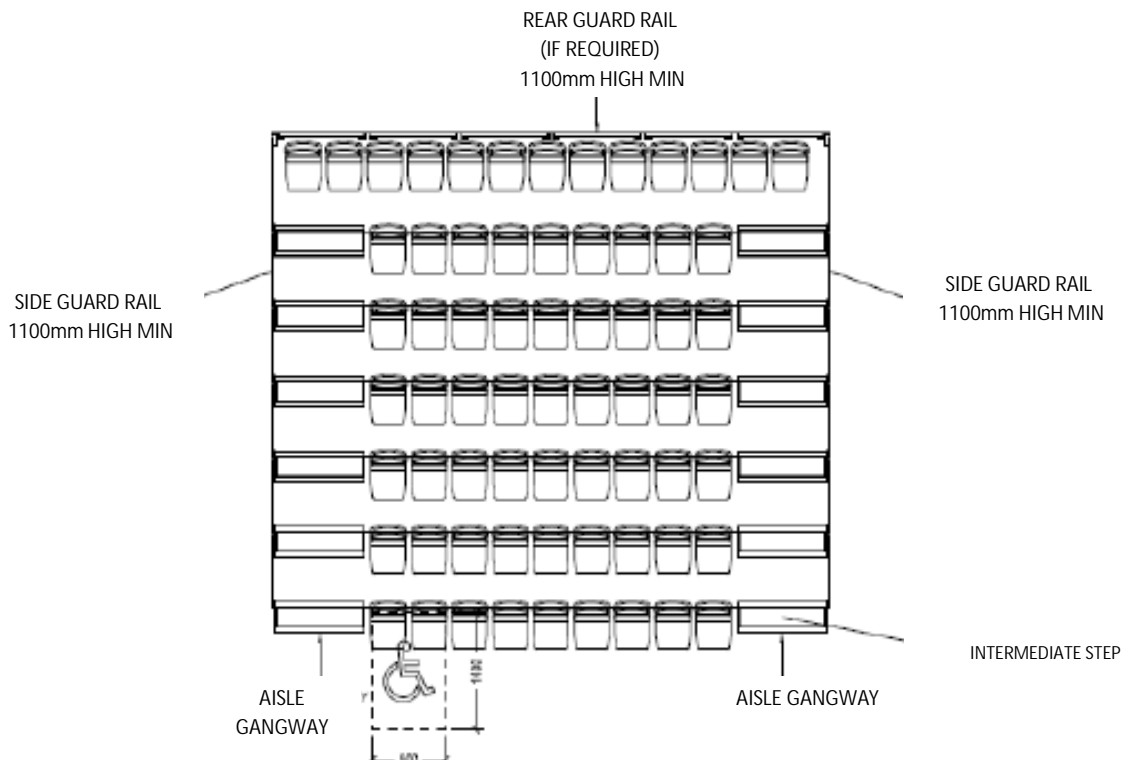



Figure 9 Typical retractable seating sectional detail

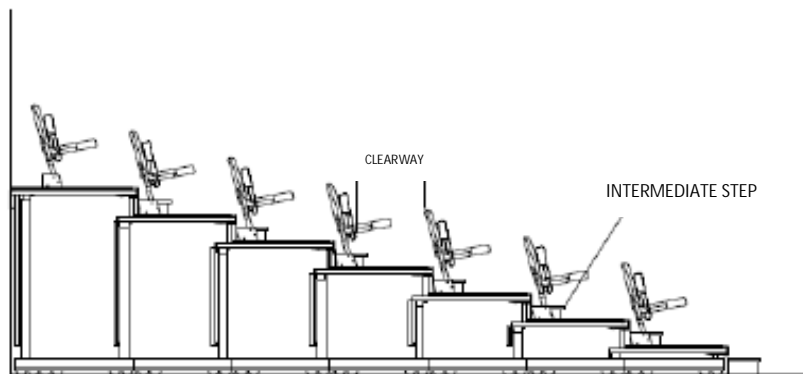

Figure 10 Typical fixed (theatre) seating detail

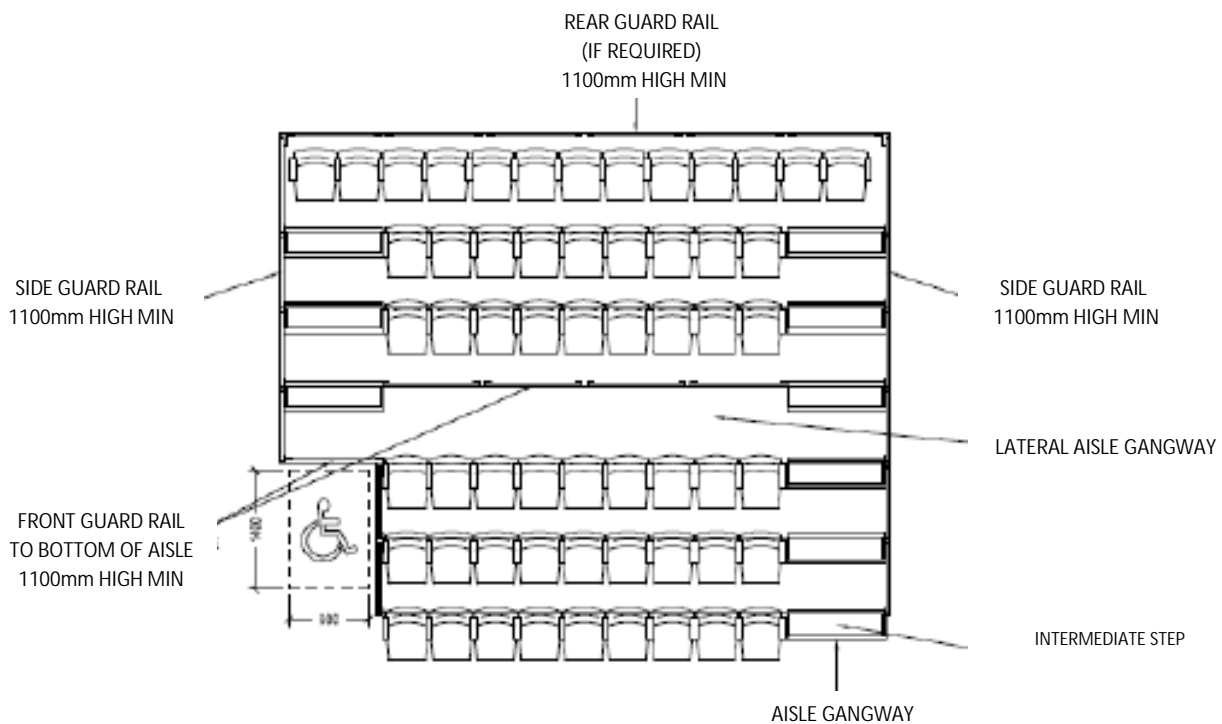
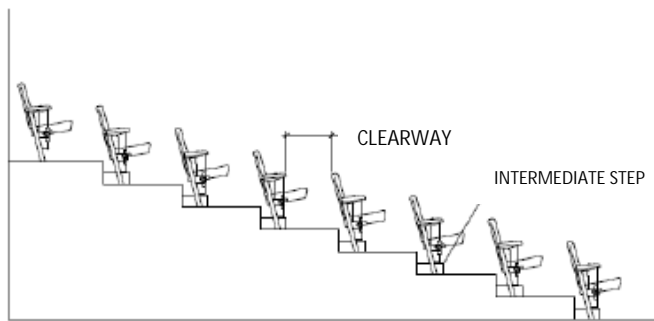
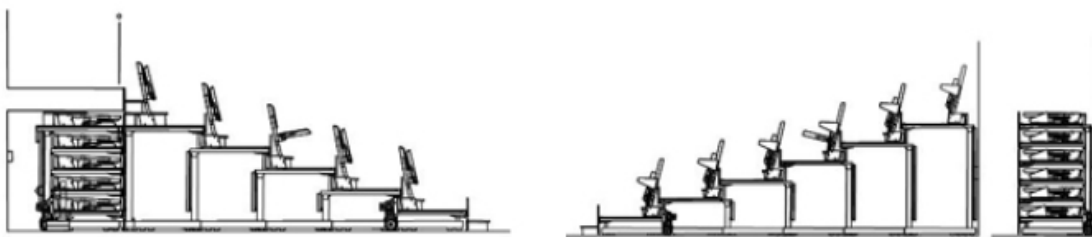



Figure 11 Typical fixed (theatre) seating sectional view



1.13 RETRACTABLE SEATING UNIT TYPES



RECESSED:
Wall or floor attached units storing in a recess provided in the Building. Possibility of top loading from balcony or rear gallery.

WALL / FLOOR ATTACHED:
Permanently located retractable seats, fixed to wall and/or floor.



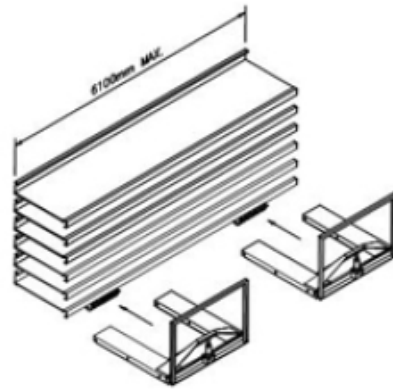

PORTABLE:

Free standing units equipped with special fittings enabling the units to be lifted and moved to another location. Moving can be achieved by integral, portable dollies or air flotation units.





LAYOUT RECOMMENDATIONS

2.1 SEATWAY

Maximum number of seats as table below:

Normally there should be not more than 14 seats in a continuous row, where there is a gangway at each end and not more than 7 seats in a row where there is a gangway at one end only. Gangways must be of adequate width for the number of seats served but must, in no case, be less than 1.100m wide.

Table 1

Number of Seats in a row		
Seatway width in row (mm)	Gangway	
	One side	Two sides
300-324*	7	14
325-349*	8	16
350-374	9	18
375-399	10	20
400-424**	11	22
425-449	12	24
450-474	12	26
475-499	12	28
500 or more	12	limited by travel distance (see table 3)

Extracted from BS 5588 Part 6 1991*Suitable for lecture theatre **Scottish regulations start here

Table 2

Capacities of exits and escape routes	
Maximum Number of Persons	width
50	900
110	1000
220	1100
240	1200 ***
260	1300
280	1400
300	1500
320	1600
340	1700
360	1800

*** Minimum Aisle Width in Scotland

Note: Capacities of other widths exceeding 1100 mm may be obtained by linear interpretation or extrapolation. Extracted from BS 5588 Part 6 1991





Table 3
Maximum travel distances

Available direction of escape	Areas with seating in rows	Open floor areas
(a) In one direction only	m 15	m 18
(b) In more than one direction	32	45

Extracted from BS 5588 Part 6 1991

2.1.1 The maximum number of seats in a row must comply with table 1

2.1.2 The seats are to be of constant depth throughout the length of a row. Where the seats tip-up automatically it should be measured between the back of one seat unit and the maximum projection of the seat unit behind when the seat is in the upright position.

2.1.3 Seat centres to be minimum 450 mm without arms and minimum average of 490 mm with arms.

2.2 ROW RISE

In tiered seating blocks the maximum row rise should not exceed 170 mm except where introducing half steps. Minimum height of a riser should be 125 mm.

2.3 ROW DEPTH

Where seating is arranged in rows, the minimum row depth allowed for each person should be 800 mm where backs are provided or 650 mm deep where backs are not provided.

2.4 AISLE / GANGWAYS

2.4.1 Gangways should not be less than 1100 mm wide, unless in an assembly area with a capacity not exceeding 110 persons. (See Table 2)

2.4.2 The ends of all rows of seats should be so aligned as to maintain a uniform width throughout the length of a gangway, unless the escape flow would only be in one direction (i.e. access to any alternative means of escape is along the rows), in which case the gangway may widen towards the storey exit.

2.4.3 Vomitorium exits provided within the body of a seating layout should be approached from the side by transverse or cross gangways.





2.4.4 Transverse gangways and radial gangways in auditoria with tiered seating should not intersect across each other (i.e. any intersections should be 'T' junctions). Connections between gangways and transverse gangways should be offset to ensure a smooth flow to the exits.

2.4.5 In stepped tiers the height of each step in a gangway should not be less than 125 mm and should not exceed 170 mm. Where there are two or more rises to each row of seats each step should be of equal height. Minimum depth/going of a half step should not be less than 280 mm.

2.4.6 The number of steppings in a tier uninterrupted by cross-gangways should not exceed 40.

2.4.7 Where exits are approached from a stepped gangway there should be a landing at least 1100 mm deep and the width of the exit immediately in front of the exit doors.





STRUCTURAL RECOMMENDATIONS

3.1 UNDERSTRUCTURE

In addition to the self weight of the structure and seating the system should also be designed to withstand:

Imposed loading in accordance with Table 7 of BS 6399 Part 1: 1984 which requires 4.0 KN/m² for the seated areas, and 5 KN/m² or a concentrated load of 4.5 KN/m² for aisle or gangway.

The structure should be capable of withstanding a minimum horizontal load equivalent to 5% of the above figures. Note: Loading applicable only when units are open or deployed.

3.2 GUARDRAILS/ SEPERATION UNITS

3.2.1 All Guardrails should be constructed such that a 100 mm dia sphere cannot pass through any part of it.

3.2.2 Guardrails adjacent to seating rows should be designed to suit BS EN 13200-5: 2006 (Telescopic Stands) and so with stand a horizontal load of 1kN/m at 1100mm high.

3.2.3 Guardrails adjacent to an aisle or gangway should be designed to withstand a horizontal load calculated to 1100m m above floor of 1.5KN/m.

3.2.4 Rear guardrails should be designed to withstand a horizontal load of 1.5kN/m at 1100mm high or 1kN/m if designed to be 1100mm above seat level.

3.2.5 Front Guardrails should be designed to withstand a horizontal load at 800 mm of .75KN/m. Where front rails are positioned at the bottom of an aisle the minimum height of the rail should be 1100m m and should be designed to withstand a horizontal load at the top of the rail of 1.5KN/m per metre run.

3.2.6 All Guardrails should be a minimum height of 1100mm except with the exception of front Guardrails which can be reduced to 800 mm to facilitate sight lines, providing it is not in an aisle position in front of seats only.





3.2.7 Front rails are to be provided to all Seating units except in the following cases:

- a) Where a bench seat is provided to the first riser.
- b) Where a row of seats is securely positioned immediately in front of first riser.
- c) Where row 1 is less than 340mm complete with an intermediate step to the whole width

Ideally chairs are captivated to the front of the unit

PARTICULAR RECOMMENDATIONS RELATING TO SPECIFIC TYPES OF SEATING

4.1 PORTABLE CHAIRS ON FLAT FLOORS

4.1.1 Temporary provisions for a close seated audience should comply with the previously stated layout recommendations

4.1.2 All chairs or other single seats (except chairs in boxes or other similar enclosures) should be linked together in rows by means of a secure linking device. The linking device should prohibit chairs from becoming unintentionally unlinked in the event of an emergency evacuation. It is recommended that provisions should be made for temporary floor fixing to the rows of seating flanking the front, back, cross gangways and also the seats nearest to exits. The method of temporary floor fixing can be by way of floor fixing bars (see note below). Floor fixing bars are often required at the end of each row, but intermediate floor bars should be considered.

NOTE: Where the permanent fixing of seating to the floor is impracticable or undesirable (e.g. on polished dance floors), floor bars instead of screws may be used. Floor bars should have a cambered top surface so as to avoid the risk of tripping up persons entering or exiting the row.



Figure 12 – Floor Bar



Figure 13- Floor Bar Clamped





4.1.3 Where seats are secured together it should not be possible to separate them, nor for a row to 'snake', in such a way that it adversely affects the row depth or walkway.

4.1.4 Where seating normally designed for use on flat floors is placed on tiered platforms of any type these should always be securely fixed.

4.2 TELESCOPIC SEATING

4.2.1 Arrangements should be made to ensure, by locking devices or other suitable means, that each stepped platform in a telescopic unit is rigid in the fully extended position and cannot retract.

4.2.2 The height to width ratio of mobile telescopic units when the units when closed should not exceed 3:1 in cross section, to ensure stability.

4.2.3 Where gangway/aisle lighting and/or power operation is specified it should comply with the relevant I.E.E. Electrical Standards and Specifications.

4.2.4 A clearly visible label should be applied to each unit stating the maximum number of seating positions that the unit is designed to accommodate.

4.2.5 Telescopic seating should only be used in accordance with the Manufacturer's Instructions and deployed only in accordance with layouts approved by local and/or Licensing Authorities.

4.3 GENERAL

4.3.1 The strength, stability and test methods for seats (chairs) can be found in BS EN 12727

4.3.2 Upholstered seating to comply with BS5858:2006 Ignition source 5 in respect of flame retardancy and contain only CMHR foam.





Notes

